

# PLANNING AND ASSEMBLY

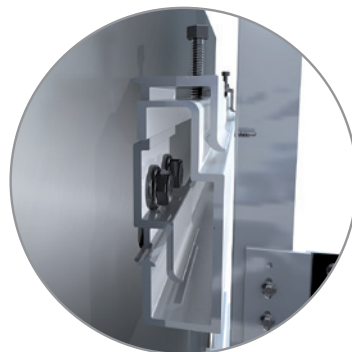

**BEMO-BOND /  
BEMO-BOND INVISIO**



## TABLE OF CONTENTS

<b>1.</b>	<b>PRODUCT DESCRIPTION</b>	<b>4</b>
1.1	Material description and composition	4
1.2	Structure and properties	5
1.3	Services and performance	5
<b>2.</b>	<b>THE BACK-VENTILATED CURTAIN FAÇADE SYSTEM (VHF)</b>	<b>6</b>
2.1	Principle	6
2.2	Characteristics	6
2.3	The advantages of the VHF	7
<b>3.</b>	<b>BEMO FAÇADE SYSTEM</b>	<b>8</b>
3.1	The advantage of the BEMO-BOND panels	8
3.2	The advantages of the TEKOFIX substructure system	8
<b>4.</b>	<b>COLORS AND FORMATS</b>	<b>9</b>
4.1	Standard and stock colors	9
4.1.1	BEMO-FLON properties	10
4.2	Formats	10
4.2.1	Large-size panels	10
4.2.2	Individual formats	10
<b>5.</b>	<b>TRANSPORT AND STORAGE</b>	<b>11</b>
5.1	Transport	11
5.2	Storage	11
5.3	Protection film	11
<b>6.</b>	<b>CLEANING AND MAINTENANCE</b>	<b>12</b>
6.1	Specific recommendations	12
6.2	BEMO-CLEAN Cleanser	12
6.3	Removal of graffiti	13
<b>7.</b>	<b>PROCESSING METHOD</b>	<b>15</b>
7.1	CNC machining centers (cutting, drilling, milling, edges closing)	15
7.2	Sawing with hand saws, panelsaws and circular table saws	15
7.2.1	Sawing with circular hand saw	15
7.2.2	Specification of circular saw blades	15
7.2.3	Sawing with a jigsaw	16

<b>7.3</b>	The routing and folding technique	16
7.3.1	Composite milling machine	17
7.3.2	Router	17
7.3.3	Edges close	18
7.3.4	Edge processing	18
<b>7.4</b>	Drilling / countersinking	18
<b>7.5</b>	Drilling jig for the centric pre-drilling of substructure	
7.5.1	Handle drilling jig 3.3 to 9.5 mm (for wood substructure)	19
7.5.2	Handle drilling jig 5.1 to 9.5 mm (for aluminium substructure)	19
7.5.3	Single-hand spring drilling device (for aluminium substructure)	19
<b>7.6</b>	Round bending	19
<b>7.7</b>	Information on the processing in winter	19
<b>8.</b>	<b>FASTENING</b>	<b>20</b>
8.1	Rivets on the aluminum substructure	20
8.2	Screw connection on the wood substructure	21
<b>9.</b>	<b>ASSEMBLY INSTRUCTION</b>	<b>22</b>
9.1	Preparation for assembly	22
9.2	Installation of the supporting profiles	23
9.3	BEMO-BOND processing	24
9.4	Mounting on the aluminum substructure	25
9.5	Mounting on the wood substructure	26
9.6	Overview of FLUTZ profiles	28
9.7	FLUTZ profiles mounting on a window frame	29
<b>10.</b>	<b>BEMO-BOND INVISIO - HIDDEN FASTENING</b>	<b>30</b>
10.1	Rails Mounting	31
10.2	Assembly of agraffes	32
10.3	Cladding mounting	33
<b>11.</b>	<b>TECHNICAL DATA</b>	<b>35</b>
11.1	Technical data for coatings	37
<b>12.</b>	<b>CERTIFICATION</b>	<b>37</b>
<b>13.</b>	<b>FIRE CLASS RATING</b>	<b>38</b>
<b>14.</b>	<b>TECHNICAL DETAILS - BEMO-BOND ON TEKOFIX</b>	<b>39</b>
<b>15.</b>	<b>INSPECTION AND MAINTENANCE</b>	<b>43</b>

## 1.1. PRODUCT DESCRIPTION

### 1.1 Material description and composition



BEMO-BOND composite panels are mainly used for the cladding with a back-ventilated curtain fa-çade system (VHF).

They consist of two high quality aluminium cover layers, each 0.5 mm thick, EN AW- 3105 or 3005 alloy, and a 3 mm / 5 mm thick core.

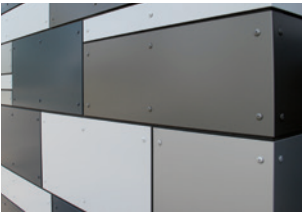

BEMO-BOND complies with the B1 (low inflammability) and A2 (non-flammable) requirements.

The visible side is painted with one of the world's highest quality coatings - BEMO-FLON coating, which is very similar to the surface of Teflon.

The innovative manufacturing process ensures the excellent peeling resistance of the sheets, which is more than twice the recommended guide values.



Open edge



Closed edge



Perforated panel



The routing and folding technique



### 1.2 Structure and properties

- Material: aluminium, polyethylene with fire protection equipment (B1) and core layer from inorganic filler material with a thermoplastic binding agent (A2)
- total thickness: 4 mm / 6 mm
- the general technical approval of DIBt
- approval No.: Z-10.3-703
- free format sizes: 2000 mm x 7200 mm
- high quality BEMO-FLON coating
- light thanks its low weight
- weather resistant - against wind, cold, rain and sun
- scratch resistant / "self-cleaning" - "easy-to-clean" surface
- high quality and attractive appearance
- impact and break resistant

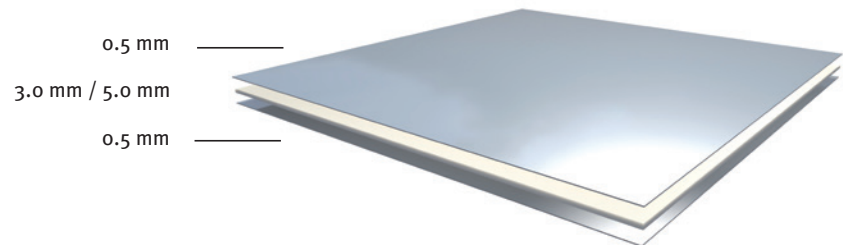

### 1.3 Services and performance

The advantage of the BEMO-BOND panels is their **attractive appearance**. Due to the **wide range of colors, shapes and formats**, they offer endless possibilities for façade design. The possibility to **close the cutting edge mechanically** can additionally refine the cladding of your building.

In addition, BEMO-BOND panels offer optimal protection of your façade against rain, wind and sun, even when laying with open joints.

They are very durable, light and easy to work like wood. These are the ideal –conditions for fast and economical assembly.

Due to the high-quality BEMO-FLON coating and the resulting large maintenance intervals, you will also save on maintenance and your investment will be redeemed in the shortest possible time.

We support you in the implementation of your project. Our engineering department offers you various engineering services: **3D dimensioning with tachymeter**, façade design and a verifiable statics for the substructure and façade cladding of all BEMO products.

With our **CNC-controlled machining** center we can supply you with BEMO-BOND, which will be cut, drilled and milled in standard or individual formats.

We can also provide you with the large-size panels and our rental equipment to process and assemble the panels yourself.

All **accessories**, such as flat sheets, flashings and fasteners in original BEMO-FLON coating, as well as the TEKOFIX substructure system can be obtained at BEMO SYSTEM GmbH. In combination with TEKOFIX you realize the most high-quality, technically advanced and energy-saving VHF.

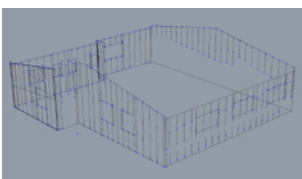

3D measurement service with tachymeter for a millimeter accuracy of the measurement.

Distance: up to 250 m

Max. dimensional deviation: 1.5 mm at 100 m distance



## 2. THE BACK-VENTILATED CURTAIN FAÇADE SYSTEM (VHF)

### 2.1 Principle

The basis for the planning and implementation of the VHF is DIN 18516-1.

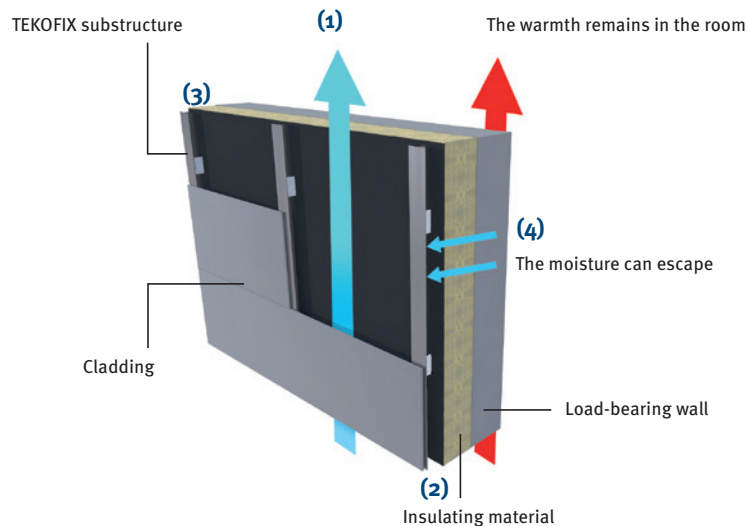

- (1) **Ventilation gap** between the outer wall (thermal insulation) and façade cladding
- (2) **Air intake opening** at the **base area**
- (3) **Air exhaust opening** on the **upper part**
- (4) **Transportation of humidity** through the outer wall

### 2.2 Characteristics

- ❖ Min. **20 mm** distance between cladding and outer wall / insulation (may be reduced locally to **5 mm**)
- ❖ **Air intake and exhaust vents** at least at the building base and at the roof edge  $\geq 50 \text{ cm}^2/\text{m}$  of the wall length
- ❖ Ventilation grilles as small animal protection for intake and exhaust air openings are required from a width of **20 mm**

In Austria all work must be carried out according to "The technical rules for building engineers".

### 2.3 The advantages of the back-ventilated curtain façade

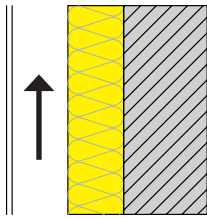

#### Moisture protection

- absolutely safe façade system
- design principle: vapor diffusion resistance decreasing from the inside to the outside
- no moisture protection calculation necessary
- avoiding of mould formation in living rooms
- healthy and pleasant indoor climate

#### The outer walls stay dry

- building moisture can be diffused outward thanks to the wall construction
- moisture caused by diffusion, dew water, rain and condensate on the back side of the cladding will be completely removed through rear ventilation

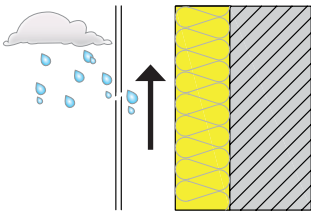

#### Driving-rain protection (even with open joints)

- about 95% rain water is derived by BEMO-BOND
- the remaining 4.5% get to the rear ventilation gap, only 0.5% reach the water-proofed insulation. Here they will be removed through the rear ventilation.
- Stress group III according to DIN4108-3

#### Building protection

- BEMO-BOND is durable, dimensionally stable, easy to maintain and very scratch resistant
- in the event of mechanical damage, individual parts are easy to replace
- the BEMO-FLON surface coating allows easy removal of graffiti

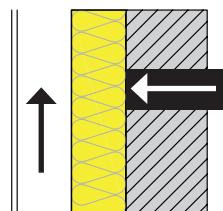

#### Winter thermal protection

- The thermal insulation can be adapted to the required U-value
- TEKOFIX wall brackets are thermal bridge-free

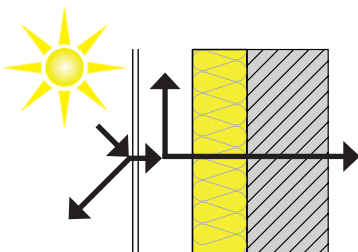

#### Summer thermal insulation

- BEMO-BOND protects the outer wall from direct sunlight
- warm air is removed through the ventilation level
- the façade insulation stores the heat during the day and releases it at night through the rear ventilation

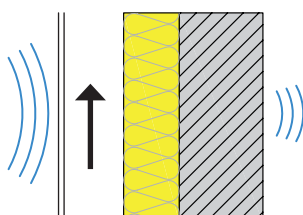

#### Sound insulation

- The VHF achieve a reduction of the sound passage from the outside to the inside and vice versa



### 3. BEMO FAÇADE SYSTEM

An ideal symbiosis with back-ventilated curtain façades.



#### 3.1 The advantage of BEMO-BOND panels

- **durable**
- **light weight**
- **easy to assemble**
- **Corner lipping by the routing and folding technique up to 135°**
- **Machining tools as rental equipment** available (composite milling machine, sliding guide rail systems, rechargeable rivet tool)
- **factory machining** through our own CNC machining center (cutting, drilling, milling, edges closing) in the format up to 4200 x 1270 mm
- **high dimensional stability** even with large panel formats
- **excellent stability**
- **long substructure spacing**
- **can be mounted on the aluminium and wood substructure**
- **high aesthetics** thanks to  **closed edges** with open joint
- **consulting services and planning support**
- **technical field service** on site
- **3D measurements with tachymeter**
- **in-house engineering department** (installation plans, verifiable statics etc.)
- **BEMO-FLON surface coating**
- **low maintenance cost**
- **40.000 color possibilities** from 500 m2
- **color-matched accessories** (edge parts, flat sheet, fasteners)
- **appropriate accessories**, all from one source (also TEKOFIX substructure system)
- **building material class B1** (low inflammability)  **and A2** (non-flammable) according to DIN 4102-1

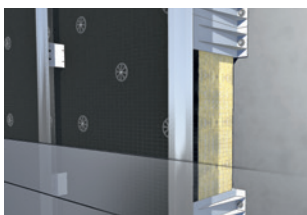

**TEKOFIX** 

#### 3.2 The advantages of the TEKOFIX substructure system

- **thermal bridge-free**
- **U-value and insulation thickness determination** in accordance with the Energy Savings Order (EnEV - Germany) taking into account the thermal bridge effect by anchoring (FEM-Finite element method)
- **reduction of energy consumption** compared with aluminium wall holders by about 75%
- **slim wall construction** with back-ventilated curtain façade
- **fully recyclable**
- **installation plans and verifiable statics** from a single source



## 4. COLORS AND FORMATS





### 4.1 BEMO-FLON Standard and stock colors

Standard colors: minimum quantity from 450 m<sup>2</sup>, delivery time by appointment. Smaller quantities are available on request.

\* Stock colors: are available in short term and in small quantities.

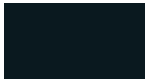

#### Color series "metallic" (matte)

			
similar RAL 7016 Anthracite metallic 15 gloss units *	similar RAL9006 Silver metallic 15 gloss units *	similar RAL9007 Grey metallic 15 gloss units *	Manganese metallic 15 gloss units *

#### Color series "natural" (matte)

				
Sandstone metallic 15 gloss units	Red Terra metallic 15 gloss units	Naturalgreen metallic 15 gloss units	Azure metallic 15 gloss units *	Bronze metallic (504) 30 gloss units *

#### Color series "elegant"

					
Ink black (326) 30 gloss units *	Smoke Silver (501) 30 gloss units *	Grey metallic (502) 30 gloss units *	Champagne Silver (503) 30 gloss units *	Deep Grey metallic (505) 30 gloss units *	Charcoal (551) 30 gloss units *
					
Sunrise Silver (600) 30 gloss units *					

#### Color series "intense" (high-gloss)

				
Intense red 75 gloss units	Intensive yellow 75 gloss units	Intense orange 75 gloss units	Intense blue 75 gloss units	Intensive green 75 gloss units *

#### Standard RAL-colors (matte)

					
similar RAL 3003 Ruby red 15 gloss units *	similar RAL 7016 Anthracite grey (105) 30 gloss units *	similar RAL 7035 Light grey 15 gloss units * / 30 gloss units *	similar RAL 9001 Cream white 30 gloss units	similar RAL 9010 Pure white 15 gloss units * / 30 gloss units *	similar RAL 9016 Traffic white 15 gloss units * / 30 gloss units *

You can obtain goods on stock in Class B1 (low inflammability). BEMO-BOND in Class A2 (non-flammable) are available on request.

Additional 40,000 color options in BEMO-FLON quality (according to RAL - or NCS color system). Individual adjustment of desired colors and gloss levels is possible.

All colors are printouts. The original colors may vary. We will be pleased to send you original color samples.

#### 4.1.1 BEMO-FLON properties

- ▶ For all the climatic regions suitable
- ▶ High color stability and gloss retention
- ▶ Low maintenance cost
- ▶ Extremely resistant to acids, bases, oils and the cleaner "Antigraffiti"
- ▶ resistant to infestation with fungal, algae and spores
- ▶ "Easy to clean" and scratch-resistant surface
- ▶ can be repainted in original color

#### 4.2 Formats

##### 4.2.1 Large format\*

The panels of large format have the dimensions of 4200 x 1270 x 4 mm / 6 mm (further lengths up to 7200 mm and widths up to 2000 mm are available on request).

For production reasons, the factory edges are offset  $\pm 2$  mm to either side. These must therefore be pre-lined with open joints on all sides during assembly. In this step the perpendicularity for further processing must be produced at the same time.

##### 4.2.2 Individual formats\*

Up to approx. 4200 x 1270 x 4 mm / 6 mm

\* Length tolerances for large formats of company standards  $\pm 4.0$  mm per rm.

Wide tolerances for large formats of company standards  $\pm 2.0$  mm per rm.

Perpendicularity max. 5.0 mm

## 5. TRANSPORT AND STORAGE

### 5.1 Transport

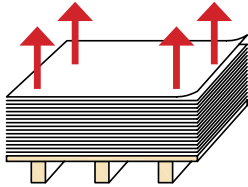

- When transporting BEMO-BOND, please note that the panels must be
- handled with care
  - checked for completeness and damage after delivery in closed pallets
  - lifted freely when unloading (at all four corners at the same time)
  - carried vertically
  - worn with gloves to avoid cutting injuries and prints
  - if they are damaged, this must be noted on the shipping documents

### 5.2 Storage

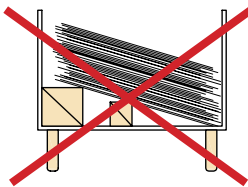

- When storing BEMO-BOND, it must also be noted that
- the panels are protected from rain and splashing water
  - if they get wet, they should be dried
  - the panels must be protected from condensing water
  - they must be stored horizontal and on a level surface
  - at the same panels format only four pallets may be stacked one over the other (the heaviest pallet must be placed at the bottom)
  - can get markings when the foreign objects are stacked in between
  - the panels are not allowed to be stored for more than eight months

### 5.3 Protection film

- In order to maintain the proper functioning of the protective film, it must be noted that
- it is protected from direct sunlight and because of this protection it may be difficult to remove the film later
  - ink markers, adhesive strips or other solvent-based substances or plasticizers get through the protective film and thus can attack the surface
  - in the event of partial removal of the film, dirty edges can occur in the course of time, which may be difficult to remove
  - the protective film should be removed immediately after assembly
  - the protective film should not be removed at the temperature below 10°C
  - the protective film in the area of the screw connection/riveting should be partially removed before fastening

## 6. CLEANING AND MAINTENANCE

### 6.1 Specific recommendations

Leaves, grass, rust or other foreign objects must be removed from the façade. Dirt in places where it is not naturally cleaned with the rain should be cleaned regularly. All the damages that can cause early wear of coatings or aluminium corrosion must be repaired. If this is not possible, the element must be replaced.

#### Are not suitable for cleaning

- ❖ highly alkaline agents, such as potassium hydroxide, soda, sodium hydroxide acids, chlorine, etc.
- ❖ anti-inflammatory agents
- ❖ agents, such as paint thinners, cleansing spirit, etc.
- ❖ brushes or rough sponges and rough clothes

**Recommendation:** test clean a small area of sample piece first.

### 6.2 BEMO-CLEAN Cleanser



#### System description

BEMO-CLEAN X500 = Graffiti and façade cleanser  
 BEMO-CLEAN X510 = final cleanser

#### Product description

BEMO-CLEAN X500 is a special cleanser for the removal of dirt and graffiti on the painted surfaces. In combination with BEMO-CLEAN X510 an effortless graffiti removal of fast all kinds is possible.

BEMO-CLEAN X500 affects very well on many of the graffiti spray paints and water based felt markers. BEMO-CLEAN X500 is also suitable for bitumen and bitumen-based graffiti spray paints.

BEMO-CLEAN X510 is a special solvent-free concentrate for the cleaning of surfaces treated with BEMO-CLEAN X500.





### 6.3 Removal of graffiti

#### Treatment

BEMO-CLEAN X500 may be manually applied with a sponge or an absorbent paper wipe. Also suitable for all air pressure spraying system, such as a pump bottle.

In most cases, the graffiti can be removed with the wiping cloth. If necessary, an exposure time of about 5-10 minutes is required. After removal of the contamination, the residues of BEMO-CLEAN X500 must be wiped with a diluted solution of BEMO-CLEAN X510 and thoroughly rinsed with water. BEMO-CLEAN X510 can be diluted with water, but the minimum concentration must not fall below 3%. The surface should be heavily contaminated, and could not be removed after the first cleaning cycle, the application of BEMO-CLEAN X500 and X510 must be repeated. If the graffiti is several months old or particularly difficult to remove, we recommend extending the exposure time.

**Important:** Before application it is essential to check on a subordinate point (e.g., back of the building), whether BEMO-CLEAN X500 and X510 leads to a damage of the subsurface (e.g. color, degree of gloss or softening of the painting, etc.).

#### Technical data

Appearance	slightly thickened liquids (concentrate)	
Color	clear to yellowish	
Packing	1 l bottles	
Storage stability	24 months Keep in frost-free conditions and in closed, original packaging. Protect from direct sunlight and temperatures > 50 °C. Ventilate storage and work areas sufficiently.	
Waste disposal	Dispose the damaged bottles (residues) and time-expired material as special wastes at the appropriate collection point, VeVa Code 08 01 11	
Thickness (20°C)	<b>X500</b> approx. 0.95 g / cm <sup>3</sup>	<b>X510</b> approx. 1.1 g / cm <sup>3</sup>
pH value	3.7	10
Flash point	<b>X500</b> 78°C	<b>X510</b> < 100 °C
Danger class	not submitted	not submitted
RID/ADR		
VOC-Wert: EU	28%	0%
CH	0%	0%

Manufacturer: MONOPOL AG, CH-5442 Fislisbach

**Special notes**

The information in this technical data sheet is based upon the general state of technology and is intended for the use of qualified staff. Deviations from the recommended processing process as well as from the specified environmental conditions can significantly affect the result. Our warranty extends solely to the quality of the delivered material. We accept no responsibility for the processing. We recommend you to contact our technical service in case of doubt. Our products are continuously improved. Therefore, please note the date of the leaflet and request the latest edition.

**Security arrangements**

When applying BEMO-CLEAN X500 and X510, ensure that the appropriate protective clothing (see Safety Data Sheet) is used.

## 7. PROCESSING METHOD



### 7.1 CNC machining center

- Separation
- Drilling
- Milling
- Automatic tool changer
- Max. panel size: 4200 x 1270 mm with stock material  
7300 x 2000 mm with special material
- Preload mechanism: vacuum



### 7.2 Sawing with hand saws, panel saws and circular table saws

BEMO-BOND can be separated with conventional hand saws, panel saws and circular table saws and the recommended saw blades. Make sure that the table is free of chips in order not to damage the surface. Therefore, vertical panel saws should be preferred. To increase the service life and avoid burr formation, a speed reduction is recommended.



#### 7.2.1 Sawing with circular hand saw

Particularly suitable: FESTOOL hand saw, type TS 55 EBQ-Plus-FS, speed 2000 - 5200 rpm  
**Pay attention to speed reduction when processing façade composite panels (approx. 2400 rpm)!**



#### 7.2.2 Specification of circular saw blades

##### Description

For aluminium panels and profiles as well as for hard and fibre reinforced plastics.

##### Trapezoidal flat tooth saw blade (TF)

The edges of the teeth are chamfered on both sides when using the trapezoidal tooth. It changes with the flat tooth during the gearing with the material. This tooth shape is used for sawing aluminum, hard plastics and hard-coated materials.



##### Technical data

Diameter	160 mm
Cutting width	2.2 mm
Drilled hole Ø	20 mm
Number of teeth	52
Rake angle	-5°
Tooth shape	TF

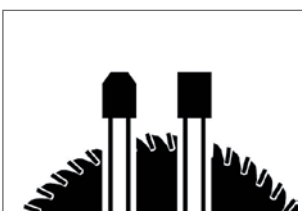



**7.2.3 Sawing with a jigsaw**

Jigsaw with pendulum stroke

Saw blades for aluminium tooth pitch = 2 mm, e.g. FESTOOL saw blade HS 60/2 bi

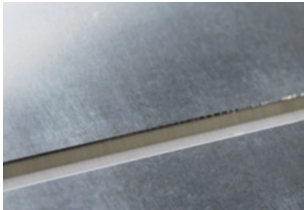

**7.3 The routing and folding technique**

BEMO-BOND can be formed with an extremely easy processing technique. The routing and folding technique allows the production of molded parts of various types, sizes and shapes.



V - shaped grooves are milled on the back using disc or shaped cutters. At the same time the aluminium cover plate at front side and 0.3 mm of the core material remain not milled. The small thickness of the remaining material then allows a bending by hand. A bending machine is not required. The groove shape determines the bending radius.

Optional with groove for edges up to 90°

The production of the grooves can be fulfilled with a CNC machining center or a vertical panel saw with routing device. For the manual execution of the milling there are composite milling machine or special cutting tools for routers.

The routing and folding technique is suitable for BEMO-BOND panels with all standard surfaces.

- a) Edges at  $\leq 90^\circ$  with tools whose angles achieve a perfect cut of  $90^\circ$ .
- b) The edges between  $90^\circ < 135^\circ$  with tools whose cutting angle achieves a perfect chamfering to the desired dimension.
- c) Folding and edging along the milled edge provides the desired panel size.

**Recommendation**

- ❖ V-groove only for the outside corner
- ❖ round nut for inner corner

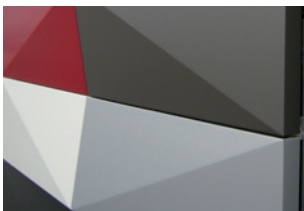

3D façade surfaces

**Advantages**

- ❖ Simple processing technology
- ❖ No open, visible cutting edges
- ❖ High efficiency - no connectors needed
- ❖ Low transport costs - bending can be done on site
- ❖ Cost-effective production of molded components, such as façade elements, frames, roof edge and attic covering, closures, corner elements and many more.
- ❖ Variety of design options
- ❖ Tension-free folding, therefore no warping in the corner area and thus simple elements
- ❖ 3D façade surfaces are possible





### 7.3.1 Composite milling machine

For example, FESTOOL composite milling machine PF 1200 E-Plus  
Please observe the FESTOOL operating instructions!

#### Characteristics

- ✦ Light weight for easy transportation and mobile applications
- ✦ Guide slot for guide rail
- ✦ Fast milling progress for easy and precise working due to side milling cutter
- ✦ Robust and low-wear design for long service life

#### Application examples

- ✦ 90° and 135° grooves creation
- ✦ milling of aluminium composite panels
- ✦ mobile use - also with guide rail



**V-grooving milling cutter** for the composite milling machine PF 1200

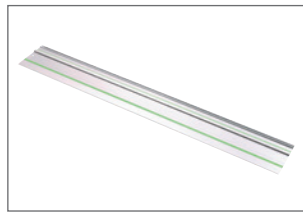

**Guide rail** for the composite milling machine and circular hand saw

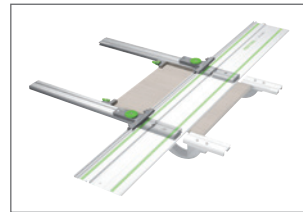

**Rip fence** for the composite milling machine and circular hand saw



**Combination bevel** for the composite milling machine and circular hand saw



### 7.3.2 Router

For example, FESTOOL router OF 2200 EB-Plus  
**Please observe the FESTOOL operating instructions!**

#### Application examples

- ✦ Folding, grooving and profiling
- ✦ Large cutouts, circles and arcs milling with the multi-routing template

#### Accessories

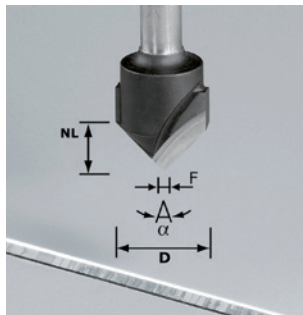

**V-grooving milling cutter** (for router) HW S8 Di8-90° (aluminium) for chamfering up to 90°

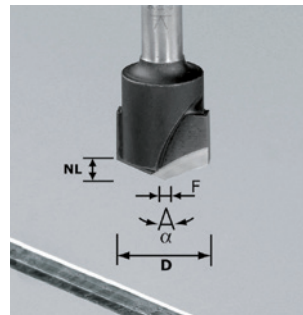

**V-grooving milling cutter** (for router) HW S8 Di8-135° (aluminium) for chamfering up to 135°



closed cutting edge  
invisible plastic core



normal cutting edge  
visible plastic core

### 7.3.3 Edges close

It is recommended to close all formed edges. In addition to the improved optics, such edges also protect against cutting injuries.

In order to easily bend such narrow edges, which have been milled according to the routing and folding technique, bending aids made from joint profiles and panel strips are recommended.



### 7.3.4 Edge processing

The edge processing can be done with the deburring tools with a rotatable blade or with a sanding fleece (3M).



### 7.4 Drilling / countersinking

BEMO-BOND can be processed with conventional aluminium and metal twist drills. Standard drills can be used. It is useful when the drills with a central end are fixable to prevent slipping and ensure perfect positioning.

**The following drills are particularly suitable:**

- ❖ drills with centering-point, e.g., DeWalt HSS-G metal drill bit DIN 338
- ❖ stainless steel drills HSS Cobalt DIN 338



### Countersink use

Countersink for deburring holes.



## 7.5 Drilling jig for the centric pre-drilling of substructure



### 7.5.1 Handle drilling jig

3.3 to 9.5 mm for wood substructure.

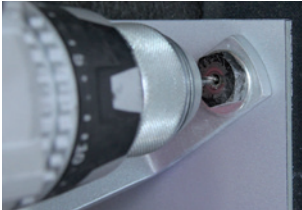

### 7.5.2 Handle drilling jig

5.1 to 9.5 mm for aluminium substructure.



### 7.5.3 Single hand spring drilling jig

For the aluminium substructure.



## 7.6 Round bending

Forced or mechanical rounding up to the smallest radii with a bending machine is easy and possible.

Please agree the requirements or radii with our technical office. We are pleased to support you.



## 7.7 Information on the processing in winter



When processing BEMO-BOND, it is necessary to ensure that the ambient and material temperature is at least 10°C.

This applies above all to the panel, which are further formed by the routing and folding technique. Because cold temperatures can cause cracks in extreme deformations.

It is fundamental to ensure that BEMO-BOND is stored in a dry place and, if possible, at room temperature. If possible, the panels should be stored in the winter at approximately 18°C for at least 24 hours before the processing operations (milling, sawing and bending) begin.

The protective film should not be removed at temperatures below 10°C. The panels can also be mounted at low temperatures.

## 8. FASTENING

### 8.1 Rivets on aluminium substructure

During the riveting of the BEMO-BOND, note that

- ❖ rivets used by BEMO with building inspection approval can also achieve an optimal color matching to the surface
- ❖ the arrangement and execution of the fixed and sliding points are taken from the façade plan
- ❖ the boreholes on the substructure are located exactly in the middle of the boreholes of the facade composite plate (using the handle drilling jig or single hand spring drilling jig)
- ❖ for the rivet tool a suitable special rivet setting device is used
- ❖ the fixed point is defined either
  - with drill hole 9.5 mm (cladding) + drill hole 5.1 mm (substructure) with fixed point sleeve
  - or
  - with drill hole every 5.1 mm (cladding and substructure) without fixed point sleeve



**Façade rivets**  
5.0 x 14 mm, head - Ø 14 mm  
head painted with BEMO-FLON



**Fixed point sleeve**  
9.5 x 3.5 mm with a 5.1 mm diameter hole



**Single hand spring drilling jig**



**Handle drilling jig**  
5.1 to 9.5 mm



**Rivet device ACCUBIRD®**



**Special rivet setting device**

Façade rivet 5.0 x 14 mm, head - Ø 14 mm, aluminium / stainless steel clamping area 5.5-9 mm

Details	Ø mm	Length in mm
similar RAL 7016 anthracite metal 15 gloss units	5,0	14
similar RAL 7035 light grey 15 gloss units		
similar. RAL 9006 silver metallic 15 gloss units		
similar. RAL 9007 metallic grey 15 gloss units		
similar RAL 9010 pure white 15 gloss units		
similar RAL 3003 ruby red 15 gloss units		
Azure blue metallic, 15 gloss units		
Manganese metallic 15 gloss units		
Intensive green 75 gloss units		

#### General

- ❖ Shining surfaces are more sensitive than matt ones. Therefore, great importance must be attached to a level surface of the substructure and the setting of the screw connection.
- ❖ According to DIN 18516-1, when determining the temperature difference, an installation -temperature of +20°C and the extreme temperatures specified in the building regulations are assumed. Towards the aluminum supporting profiles the temperature of 10°K of the BEMO-BOND panels is calculated.

#### Max. panel dimensions depending on the drill hole diameter and rivet head size

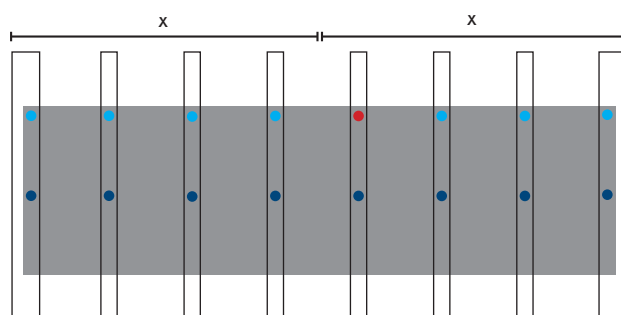

Fixed point  
Sliding point  
Fixed-sliding point

x	Drill hole	Rivet head
≤ 1.543 m	8.5 mm	K14
≤ 2.050 m	9.5 mm	K16

For larger panel lengths, please contact our technical department.



**Façade screw**  
4.8 x 30 mm, head - Ø 16 mm  
incl. sealing ring  
FA-ZE-DI-14.0 x 4 mm head,  
painted BEMO-FLON



**Handle drilling jig**  
3.3 to 9.5 mm



**EPDM joint tape**  
70 mm / 110 mm / 130 mm



**Fixed point sleeve** Ø 8.5 x 3.5 mm with a 5.1 mm diameter hole

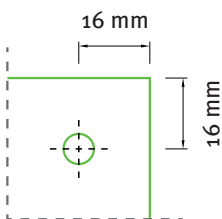

Edge distances

**8.2 Screw connection to the wood substructure**

**When screwing the BEMO-BOND, please note that**

- the wood is technically dried, planed at right angles and is torsion-free
- on the substructure an EPDM joint tape with a double-sided protrusion (each min.5 mm) is used
- system fasteners with sealing ring can be used for BEMO-BOND with general technical approval
- all holes of the cladding are pre-drilled with 9.5 mm (fixed point and sliding point)
- the wood substructure is pre-drilled centrally and angle-oriented by means of the handle drilling jig to 3.3 mm
- the screws are not tightened too tightly, so that no pressure is exerted on the panels (avoid compulsions and pressure points)
- the fixed point is always defined with fixed point sleeve

**Façade screw 4.8 x 30 mm, head - Ø 16 mm**

Details	Ø mm	Length in mm
similar RAL 7016 anthracite metal 15 gloss units	4,8	30
similar RAL 7035 light grey 15 gloss units		
similar. RAL 9006 silver metallic 15 gloss units		
similar. RAL 9007 metallic grey 15 gloss units		
similar RAL 9010 pure white 15 gloss units		
similar RAL 3003 ruby red 15 gloss units		
Azure blue metallic, 15 gloss units		
Manganese metallic 15 gloss units		
Intensive green 75 gloss units		

**Do not use countersunk screws!**

**Important**

The protective film should always be removed before screwing in the area of the screw head.

**General**

- Shining surfaces are more sensitive than matt ones. Therefore, great importance must be attached to a level surface of the substructure and the setting of the screw connection.
- According to DIN 18516-1, when determining the temperature difference, an installation -temperature of +20°C and the extreme temperatures specified in the building regulations are assumed.

## 9. ASSEMBLY INSTRUCTION

### 9.1 Preparation for assembly

The mounting of BEMO-BOND is carried out on the substructure in accordance with DIN 18516-1, taking into account the structural calculations and the installation plans (for example, TEKOFIX system - the thermal-bridge-free substructure with approval of the building inspection. Visit [www.tekofix.de](http://www.tekofix.de)).

#### Preparation of the substructure

The supporting profile must be aligned absolutely flat in order to achieve a flat surface of the cladding.

Before mounting the BEMO-BOND panels, the existing substructure must be checked for the proper mounting and stability.

The expert assembler takes the substructure from the planning documents of the façade composite panel.

#### Installation instructions-Installation direction

The alignment of the logos determines the direction of installation.

See graph.

**Reason:** the paint particles are always applied at the same angle with the sheet coating. As a result, the angle of reflection is always the same in case of light.

If the installation is not constant in one direction, there may be color differences in the view. In order to ensure a uniform surface, it is important that all panels for application or façade surface are ordered and installed from one batch.

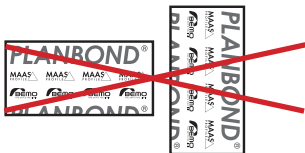

Wrong installation!

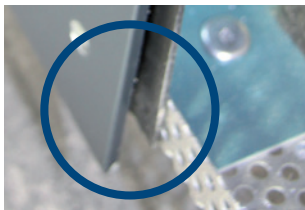

#### Avoiding the printing on the surface

When mounting the plate, it is necessary to avoid the impression of protruding anchors or rivets.

Mount the ventilation profile to the supporting profile from behind using the auxiliary angle.

Lower the anchoring agents to the substructure.





### 9.2 Assembly of the supporting profiles

(for example, on the TEKOFIX wall console)



**(1)** Clip on the holding string (mounting aid) in the TEKOFIX wall holder.



**(2)** Insert the supporting profile into the holding spring.

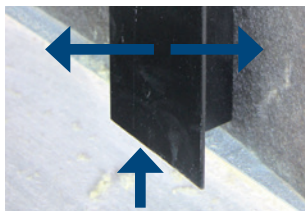

**(3)** Align the lower end of the supporting profile in height. The supporting profile should be placed perpendicularly to the wall.



**(4)** Fix the supporting profiles with the locking pliers. Screw the supporting profile to the TEKOFIX.



**9.3 Machining of the BEMO-BOND composite panels**

The machining of the BEMO-BOND can be controlled either by CNC or manually.  
**Note: the panels should always be machined on the rear side.**



**(1)**  
 The dimensions should be transferred from the installation plan on the back of the BEMO-BOND façade composite panel.



**(2)**  
 Separate the BEMO-BOND composite panels.



**(3)**  
 Drill the mounting holes.  
 Aluminium substructure:  
 all holes Ø 8.5 mm or fixed point Ø 5.1 mm; sliding point Ø 8.5 mm  
 Wood substructure:  
 All holes Ø 9,5 mm



**(4)**  
 Apply the guide rail during milling.  
 Mark = middle milling groove = outer edge (longest side) of BEMO-BOND. Place the leading edge of the template on the mark.



**(5)**  
 Mill the V-groove for the plate folding.



**(6)**  
 Fold the plate





#### 9.4 Fastening on the aluminium substructure with the rivets

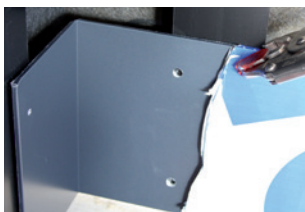

**(1)**

Align the plate and fix it with rubberized gripping pliers.  
Remove protective film in the area of the borehole before mounting.

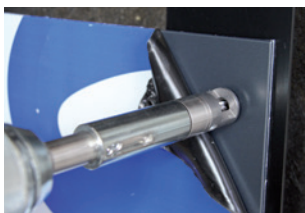

**(2a)**

Centric pre-drilling of the substructure using the single hand spring drilling jig.

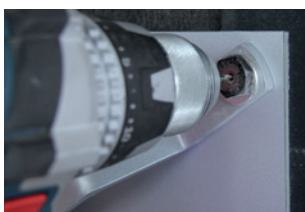

**(2b)**

Centric pre-drilling of the substructure using the handle drilling jig 5.1 mm to 8.5 mm.



**(3)**

Fixed-point performance:  
Either hole  $\varnothing$  5.1 mm or  $\varnothing$  9.5 mm with fixed point sleeve.



**(4)**

Special rivet setting device for ACCUBIRD®.



**(5)**

Remove protective film.

### 9.5 Fastening on the wood substructure



- (1)**  
Stick the wood with EPDM joint tape.

The following applies:  
Wood width + 10 mm = EPDM joint tape width



- (2)**  
Pre-drill in BEMO-BOND a hole with  $\varnothing$  9.5 mm (sliding and fixed points).



- (3)**  
Pre-drill the wood substructure using handle drilling jig with 3.3 mm to 9.5 mm holes and  $\varnothing$  3.3 mm.



- (4)**  
Insert the seal.



- (5)**  
Screw the façade fixing screw with the sealing ring to finish the installation.



### Fixed-point performance - fastening on the wood substructure



- (1)**  
Stick the wood with EPDM joint tape.

The following applies:  
Wood width + 10 mm = EPDM joint tape width



- (2)**  
Pre-drill in BEMO-BOND a hole with  $\varnothing$  9.5 mm (sliding and fixed points).



- (3)**  
Pre-drill the wood substructure using handle drilling jig with 3.3 mm to 9.5 mm holes and  $\varnothing$  3.3 mm.



- (4)**  
Insert the seal.



- (5)**  
Insert the fixed point sleeve into the seal.



- (6)**  
Screw the façade fixing screw, the sealing ring and fixed point sleeve to finish the installation.



**9.6 BEMO FLUTZ profiles overview**

For window, door and gate jambs.

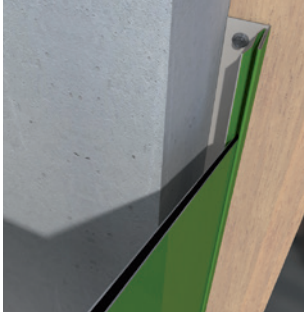

**Version 1:**  
Hidden fastening

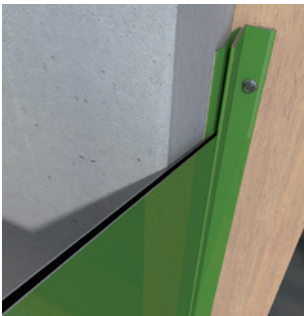
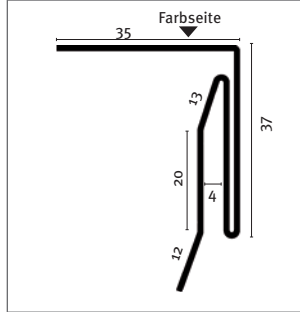

**Version 2:**  
Visible fastening

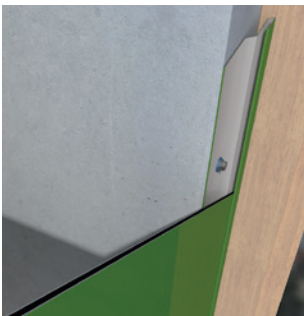
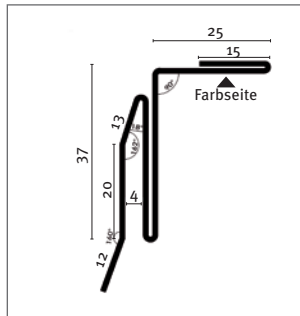

**Version 3:**  
Side mounting

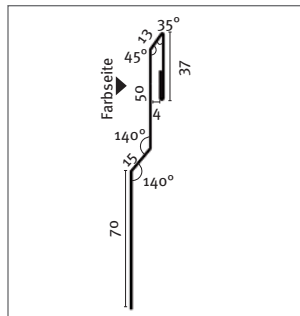

### 9.7 Installation of a FLUTZ profile on the window frame

(e.g., FLUTZ profile version 1, hidden fastening)



**(1)**

Glue sealing tape onto the FLUTZ profile.



**(2)**

Fix the FLUTZ profile.



**(3)**

Insert the BEMO-BOND composite panel into the FLUTZ profile.



**(4)**

Complete installation of the FLUTZ profiles on the window frame and connection of the window sill.

## 10. BEMO-BOND INVISIO – HIDDEN FASTENING



### The advantages

- ❖ High-quality optics thanks to hidden fastening
- ❖ Quick and easy installation
- ❖ Weather-independent installation
- ❖ Good adjustability due to individual fastening
- ❖ Choice of horizontal or vertical façade division
- ❖ The mounting of large size panels is possible
- ❖ Without complex and expensive assets assembly
- ❖ With closed cutting edges at the request
- ❖ Also available in fire classification A2 (non-flammable)
- ❖ Seamless corner lipping by the routing and folding technique
- ❖ BEMO-FLON coating
- ❖ Lower transport costs

## BEMO-BOND INVISIO

### System overview



BEMO-BOND with undercut.

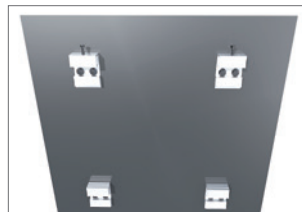

BEMO-BOND incl. milling for the assembly of the agraffes.



Vertical supporting profile and horizontal BEMO-BOND INVISIO profile panels.

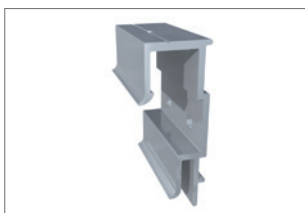

INVISIO agraffe 68 type 1 - one hole

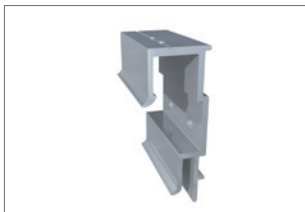

INVISIO agraffe 68 type 2 - two holes



INVISIO agraffe 68 type 3 - without hole



### Types of agraffes

Agraffe depending on application incl. screws and nuts.

Description	
Type 1 Agraffe 53/68	for the panel adjusting
Type 2 Agraffe 53/68	for the adjusting of the panel and the fixed-point performance
Type 3 Agraffe 53/68	Standard agraffe



### 10.1 Mounting the rails



(1)

Mounting perforated sheet and window sill holder for window sheet.



(2)

Transfer of the meters crack on the supporting profile.

(Meter crack = reference line for the division of the horizontal BEMO-BOND INVISIO rails).

In the installation plan the **lower edge** of the BEMO-BOND INVISIO rails is given in a continuous dimensional chain.

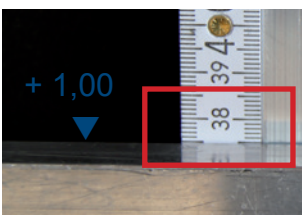
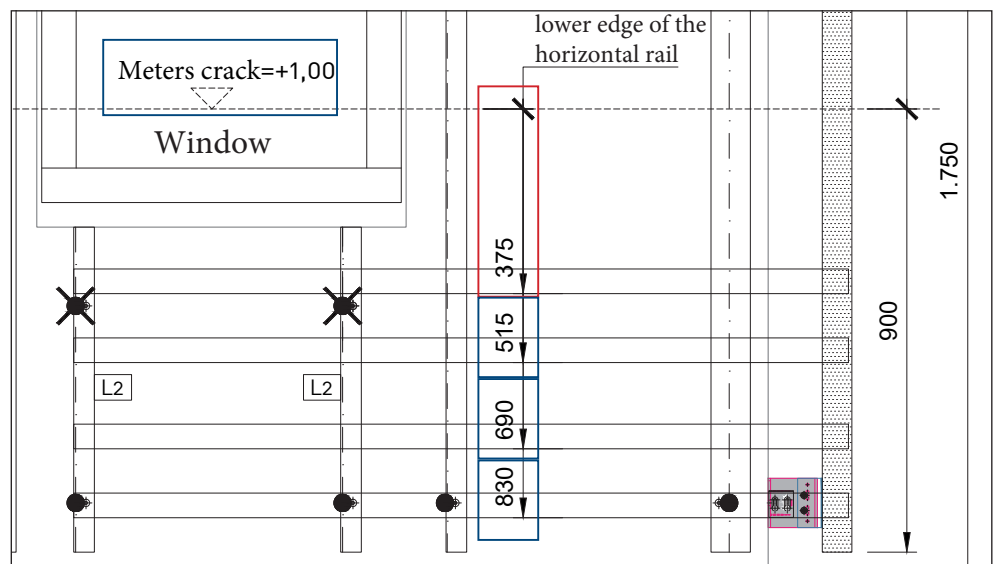

(3)

Transfer of the lower edge of the BEMO-BOND INVISIO rails on the vertical supporting profiles.



(4)

Fastening and screwing / riveting of the BEMO-BOND INVISIO rails.



(5)

Complete installation of the BEMO-BOND INVISIO rails.

10.2 Assembly of the agraffes



Type 1 Type 2 Type 3  
(Picture shows agraffe type 68)

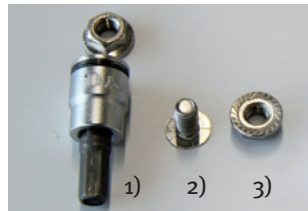
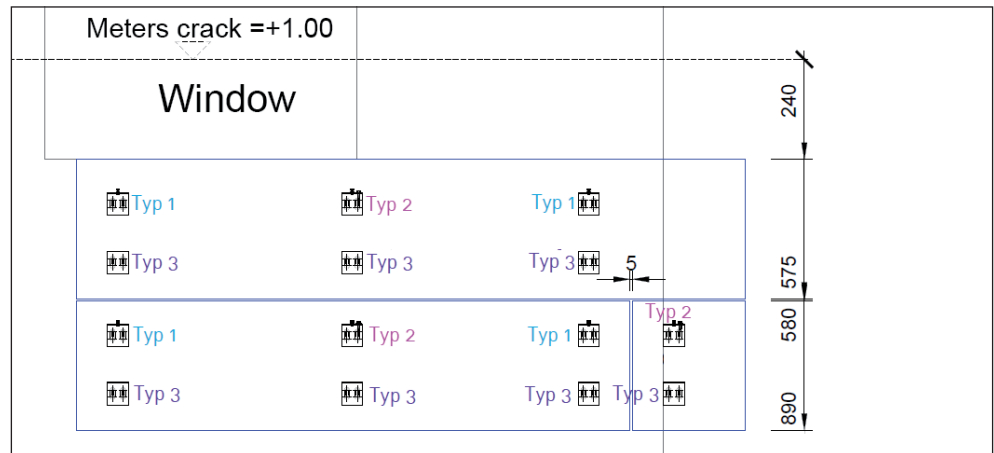

- 1) 10 mm socket
- 2) INVISIO-screw
- 3) M6 nut with serrated underhead

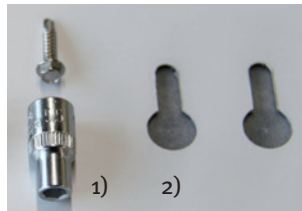

- 1) Fixed point screw with 5.5 mm socket
- 2) BEMO-BOND INVISIO Bore with undercut

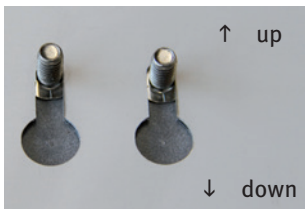

(6) Insert the INVISIO-screws in the BEMO-BOND INVISIO bore with an undercut.



(7) Screw the adjusting screw flush into the agraffe.

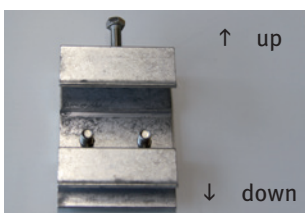

(8) Attach the agraffe to the INVISIO screw.  
**Observe its direction.**



**(9)**

The assembly of the agraffe must be carried out in such a way that it ends at the control line.

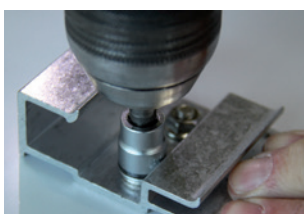
**(10)**

While tightening the M6 nut, push the agraffe up to the stop (torque = 3 Nm).

**(11)**

Pre-assembled agraffes on the BEMO-BOND panel.

Fold the BEMO-BOND panels before installing.

### 10.3 Mounting of cladding

**(12)**

Hook up the agraffes on the BEMO-BOND INVISIO rail.

**(13)**

The fixed point agraffe (type 2) → only the top row.

**(14)**

Agraffe for the adjusting (type 1) → top row only.

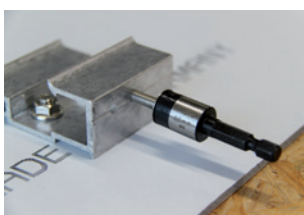
**(15)**

Adjusting screw with socket SW8.



- (16)**  
 Height adjustment.  
 Horizontal alignment of the BEMO-BOND INVISIO composite panels.



- (17)**  
 Vertical alignment of the BEMO-BOND INVISIO composite panels.



- (18)**  
 Set the fixed point screw (e.g., JT3-6-5.5 x 35 E16) with the 5.5 mm socket and a flexible bit extension.



- (19)**  
 a) Set joint distances with spacers.  
 b) Tighten the adjusting screws to the resistance.  
 c) Screw fixed-point screws.



- (20)**  
 Set window sill.



- (21)**  
 Install FLUTZ profile.



- (22)**  
 The finished installation.  
 Remove the protective film of the BEMO-BOND only after the installation is finished.

## 11. TECHNICAL DATA - BEMO-BOND 4 MM

DIMENSION			
	BEMO-BOND B1	BEMO-BOND A2	Standard
Total thickness	4 mm	4 mm	
Thickness of aluminium sheet	0.5 mm	0.5 mm	
Weight	7.6 kg/m <sup>2</sup>	8.1 kg/m <sup>2</sup>	
Max. width (according to the approval)	2050 mm	2050 mm	
Max. length (according to the approval)	7200 mm	7200 mm	
Max. width finished (factory finished)	2050 mm**	1575 mm**	
Max. length finished (factory finished)	7200 mm**	7200 mm**	
Core	Polyethylene with fire protection	Inorganic fillers with	
thermoplastic bounding agent	± 0,2 mm	± 0,2 mm	
Thickness tolerances	± 0.2 mm	± 0.2 mm	
Width tolerances	± 2 mm/rm	± 2 mm/rm	
Length tolerances	± 4 mm/rm	± 4 mm/rm	
Diagonal tolerances	max. 5 mm	max. 5 mm	
MECHANICAL PROPERTIES			
Bending stiffness E•I	230 Nm <sup>2</sup> /m	230 Nm <sup>2</sup> /m	Z-10.3-703
Resistance torque W	1,54 cm <sup>3</sup> /m	1,54 cm <sup>3</sup> /m	
Rated value of bending strength	118 N / mm <sup>2</sup>	118 N / mm <sup>2</sup>	
Can be used at temperature of	-50 < + 80 °C *	-50 < + 80 °C *	
Reaction to fire	<b>B - s1,do</b> flame resistant	<b>A2 - s1,do</b> not flammable	DIN EN 13501-1: 2010-01

TECHNICAL PROPERTIES OF THE ALUMINIUM COVERING SHEETS (CLASS B1 AND A2)			
	3105	3005	
Aluminum alloy	3105	3005	DIN EN 485-2
Tensile strength	Rm ≥ 150 und ≤ 200 N/mm <sup>2</sup>	Rm ≥ 170 und ≤ 215 N/mm <sup>2</sup>	
Yield strength	Rp0,2 ≥ 130 N/mm <sup>2</sup>	Rp0,2 ≥ 130 N/mm <sup>2</sup>	
Strain at failure	> 1 %	> 1 %	
Elasticity modulus	70000 N / mm <sup>2</sup>	70000 N / mm <sup>2</sup>	

\* The BEMO-BOND panels should be machined at temperatures above + 10°C.

\*\* Special materials

## 11. TECHNICAL DATA - BEMO-BOND 6 MM

DIMENSION		
	BEMO-BOND 6 mm, Class B1	Standard
Total thickness	6 mm	
Thickness of aluminium sheet	0.5 mm	
Weight	10.6 kg/m <sup>2</sup>	
Max. width (according to the approval)	2050 mm	
Max. Length (according to the approval)	7300 mm	
Max. Width finished (factory finished)	2050 mm**	
Max. Length finished (factory finished)	7200 mm**	
Core	Polyethylene with fire protection	
Thickness tolerances	± 0.2 mm	
Width tolerances	± 2 mm/rm	
Length tolerances	± 4 mm/rm	
Diagonal tolerances	max. 5 mm	
MECHANICAL PROPERTIES		
Bending stiffness E•I	547 Nm <sup>2</sup> /m	Z-10.3-701
Resistance torque W	2,53 cm <sup>3</sup> /m	
Rated value of bending strength	118 N / mm <sup>2</sup>	
Can be used at temperature of	-50 < + 80 °C *	
Reaction to fire	<b>B - S1, do flame resistant</b>	<b>DIN EN 13501-1: 2010-01</b>

TECHNICAL PROPERTIES OF THE ALUMINIUM COVERING SHEETS			
Aluminum alloy	3105	3005	DIN EN 485-2
Tensile strength	Rm ≥ 150 und ≤ 200 N/mm <sup>2</sup>	Rm ≥ 170 und ≤ 215 N/mm <sup>2</sup>	
Yield strength	Rp0,2 ≥ 130 N/mm <sup>2</sup>	Rp0,2 ≥ 130 N/mm <sup>2</sup>	
Strain at failure	> 1 %	> 1 %	
Elasticity modulus	70000 N / mm <sup>2</sup>	70000 N / mm <sup>2</sup>	

\* The BEMO-BOND panels should be machined at temperatures above + 10°C.

\*\* Special materials

## 11.1 Technical data for coatings

Properties	Standard	BEMO-FLON	Note	PVDF 70% Kynar 500	Note
Paint layers		2		2	
Thickness of the paint layers	EN 13523-1	26 ± 6 µ		25 ± 4 µ	
Protection primer		yes		yes	
Mirror gloss, 60°	EN 13523-2	15 ± 5 GE		30 ± 5 GE	
Pencil hardness	EN 13523-4	≥ H - 2H		≥ HB	
Adhesion	EN 13523-5 ASTM B 2794	no cracks		no cracks	7.5 Nm/mm
Adhesion & impact resistance	EN 13523-6	≤ GT 1		≤ GT 1	
T BEND	ECCA T7	1T - 2T			180°
MEK/solvent Friction test	ECCA T11	> 100 (DR @ 1 kp)		≤ 80 Double friction gen	
Salt spray resistance	ASTM B 117	3000 hours	no or low blistering	Corrosion Index 2 according to EN 1396 Table C4	after 1000 hours
Moisture resistance	ASTM D 2247	3000 hours	no or low blistering	no impact	after 1000 hours
Chalking (Light cycle test, after 500 hours)	EN 13523-14	≤ 8%	South Florida 5 years 45°	≤ 10%	South Florida 5 years 45°



## 12. CERTIFICATION

The general technical approval of DIBt

Approval No.: Z-10.3-703

### 13. FIRE CLASSIFICATION



Country	Standard	Class	
Europe	DIN EN 13501-1: 2010-01 (building fire class) ISO 5658-4 (Vertical propagation of the flame)	B - s1,do	A2 - s1,do

**Fire classes of building products Standard 13501-1**

**Class A1:** For homogeneous products (without additional classifications).

**Class A2:** For homogeneous products.

**Class B:** A product for this class shall be tested in accordance with UNE EN ISO 11925-2 with 30 s exposure time.-

**Class C:** A product for this class shall be tested in accordance with UNE EN ISO 11925-2 with 30 s exposure time.-

**Class D:** A product for this class shall be tested in accordance with UNE EN ISO 11925-2 with 30 s exposure time.-

**Class E:** A product for this class shall be tested in accordance with UNE EN ISO 11925-2 with 15 s exposure time.

**Additional classifications: s1, s2 and s3 - smoke generation.**

These additional classifications result from the measurement data of the tests according to standard EN 13823.

**Additional classifications: do, d1 and d2 - flaming droplets.**

These additional classifications result from the observations of droplets and particles in the flame:

For class E: UNE EN ISO 11925-2 (d2)

For class B, C and D: UNE EN ISO 11925-2 and EN 13823 (do, d1, or d2).

## 14. TECHNICAL DETAILS - BEMO-BOND ON THE TEKOFIX SUBSTRUCTURE

### Regular assembly

Horizontal section

Standard construction VPB-3010

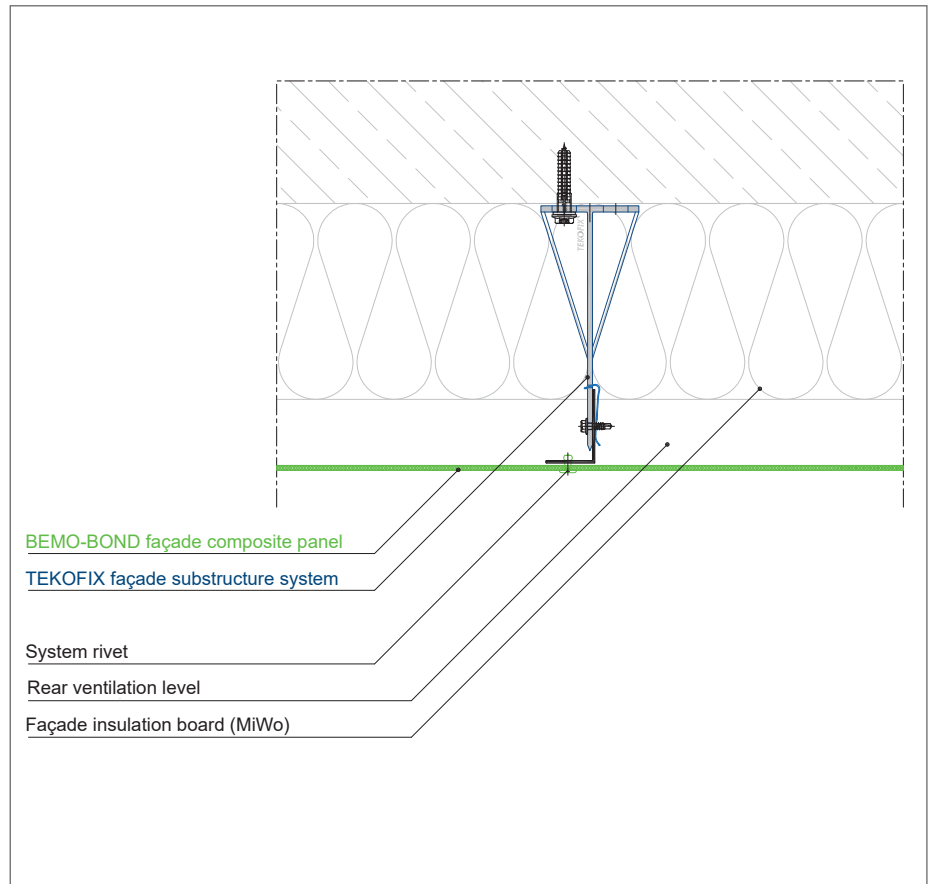

### Vertical joint

Horizontal section

Standard construction

VPB-3011

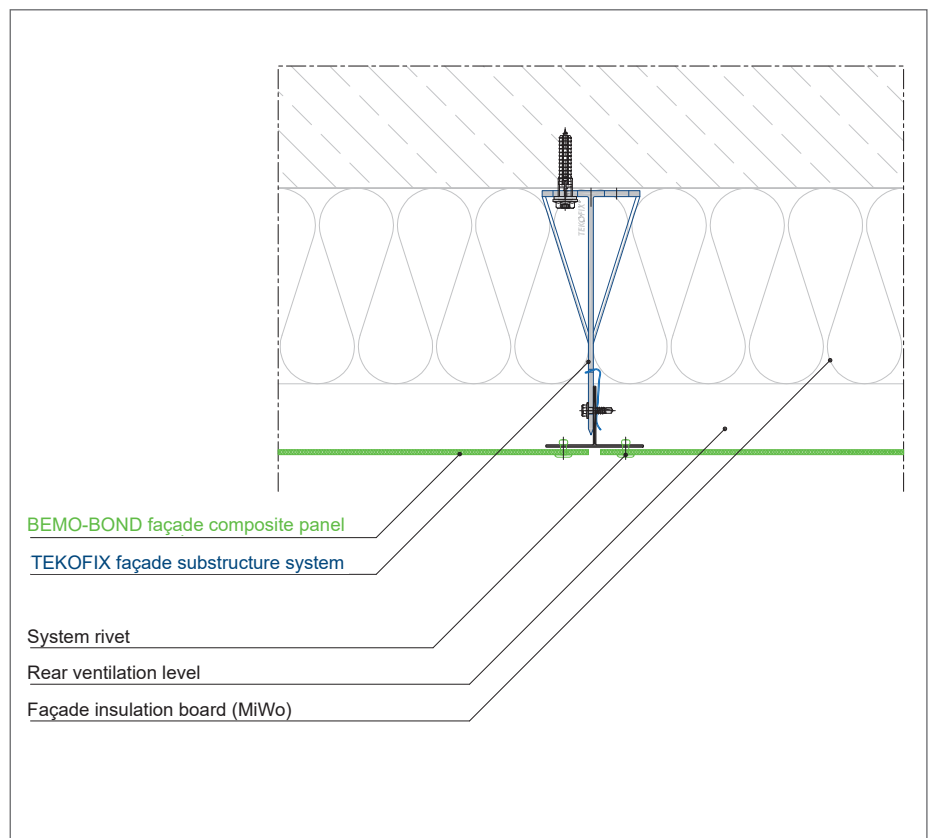

**Horizontal joint**

Vertical section  
 Standard construction  
 VPB-3012

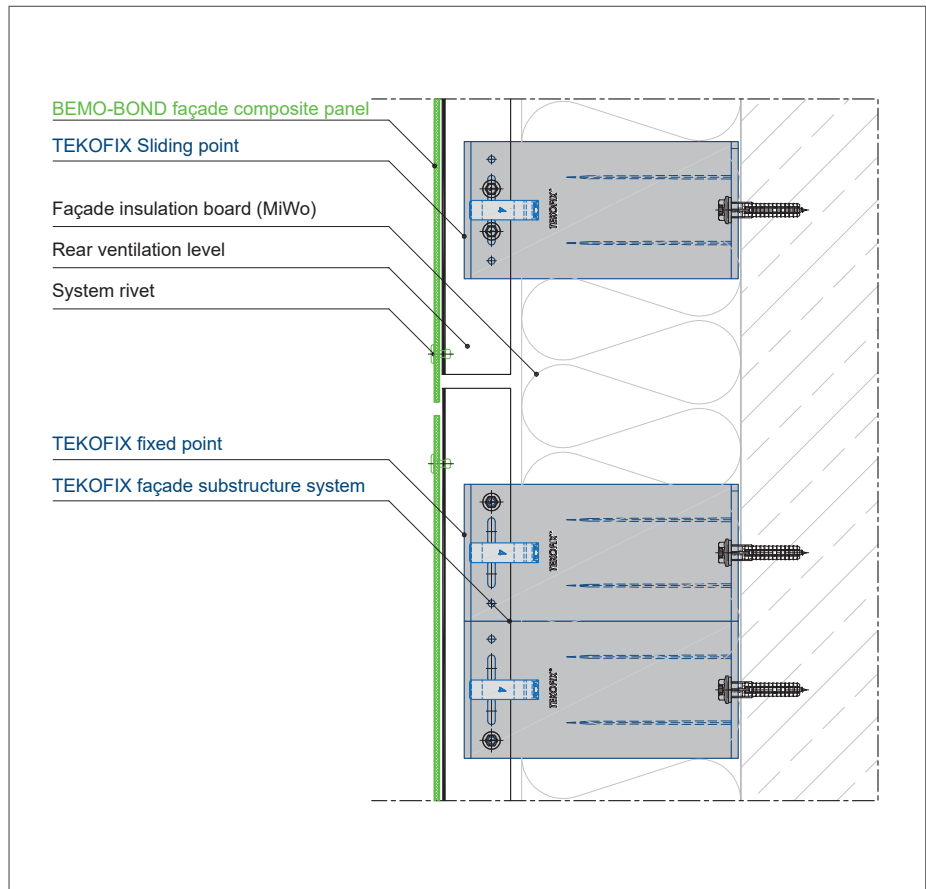

**Base joints**

Vertical section  
 Standard construction VPB-3411

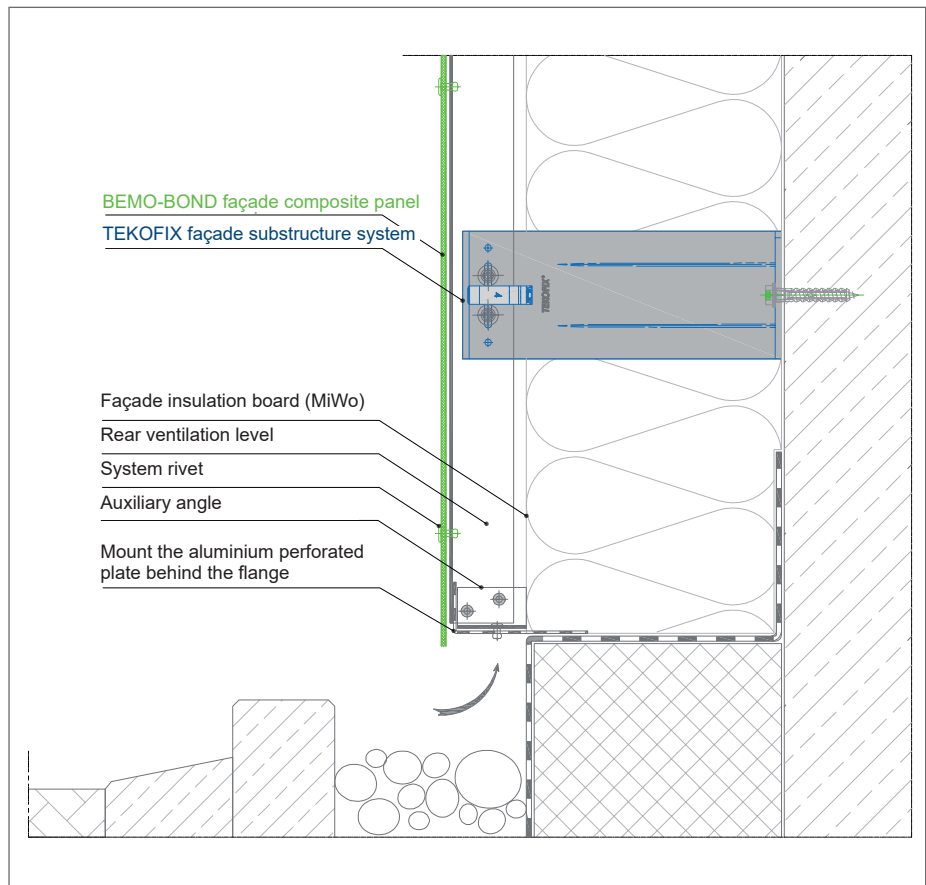



**Window connection bottom**

Vertical section  
 Standard construction  
 VPB-3611

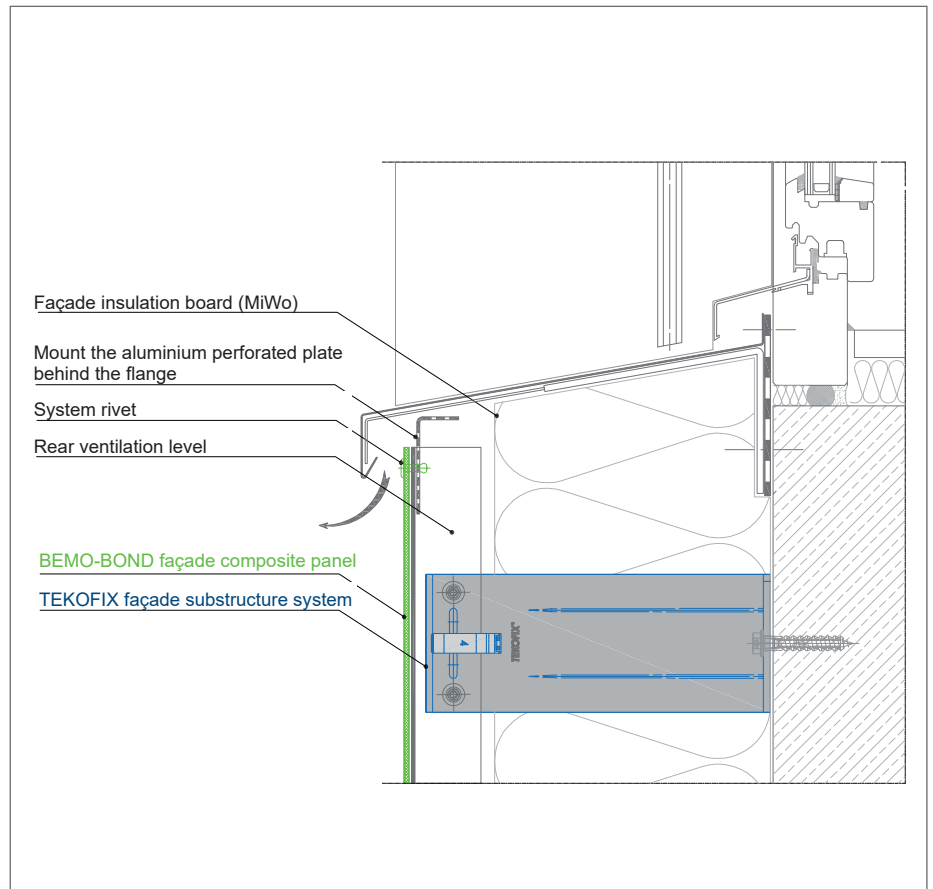

**Window connection lateral**

Horizontal section  
 Standard construction  
 VPB-3711

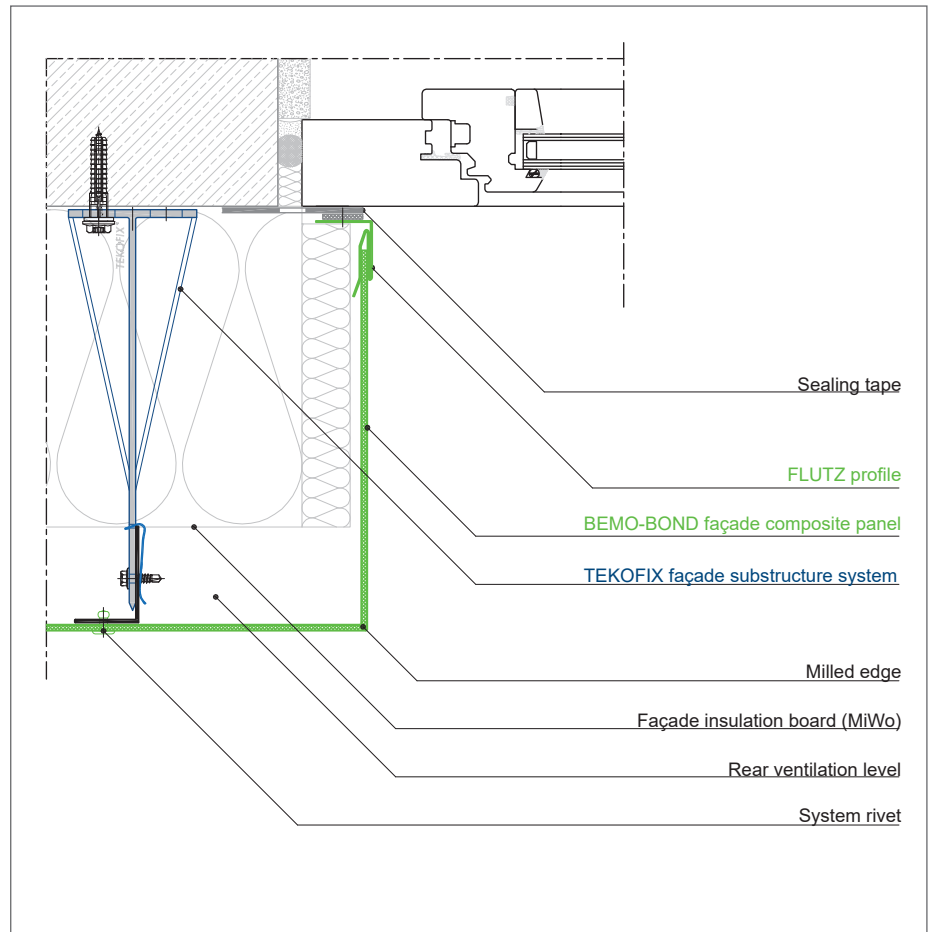

**Window connection top**  
 Vertical section  
 Standard construction  
 VPB-3213

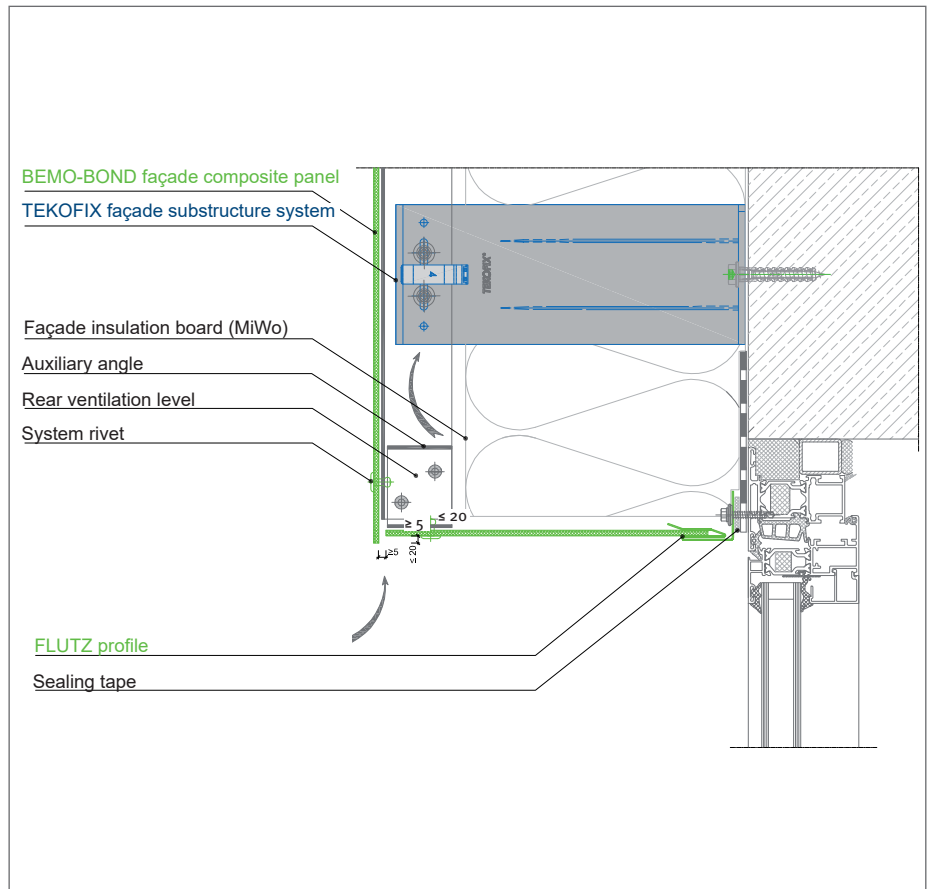

**Attic alignment**  
 Vertical section  
 Standard construction VPB-3111

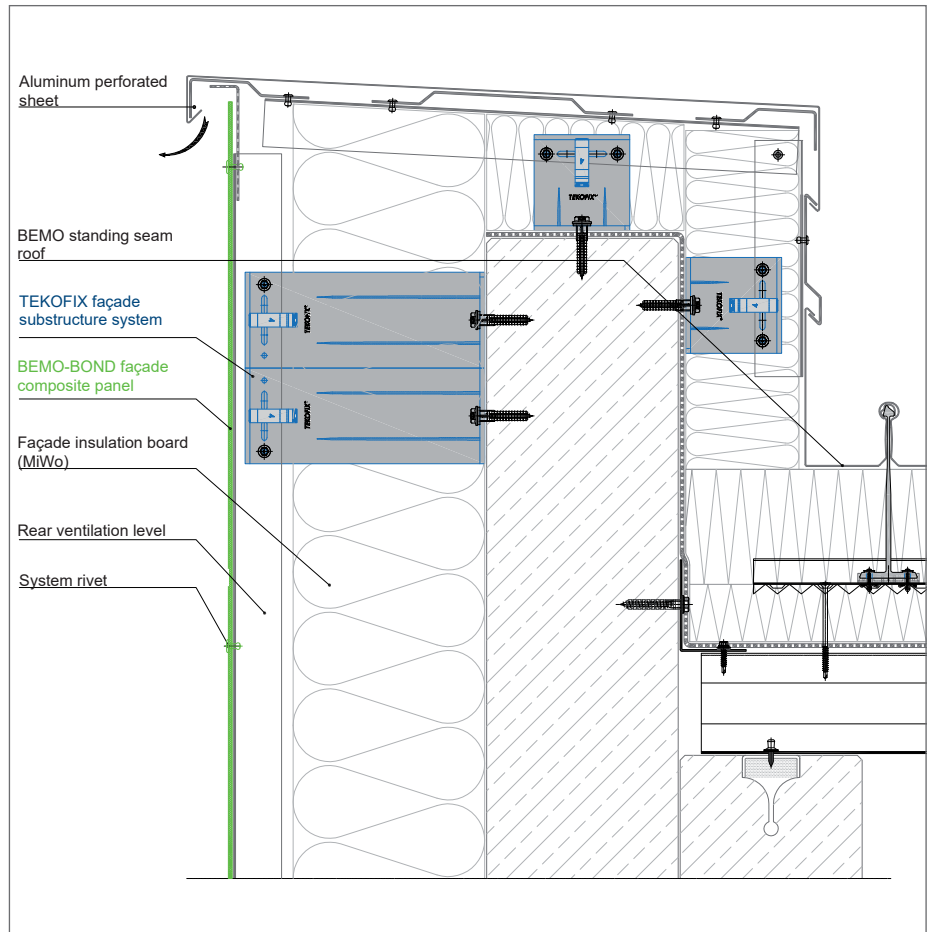

**Corner lipping/inner corner**

Horizontal section

Standard construction

VPB-3313

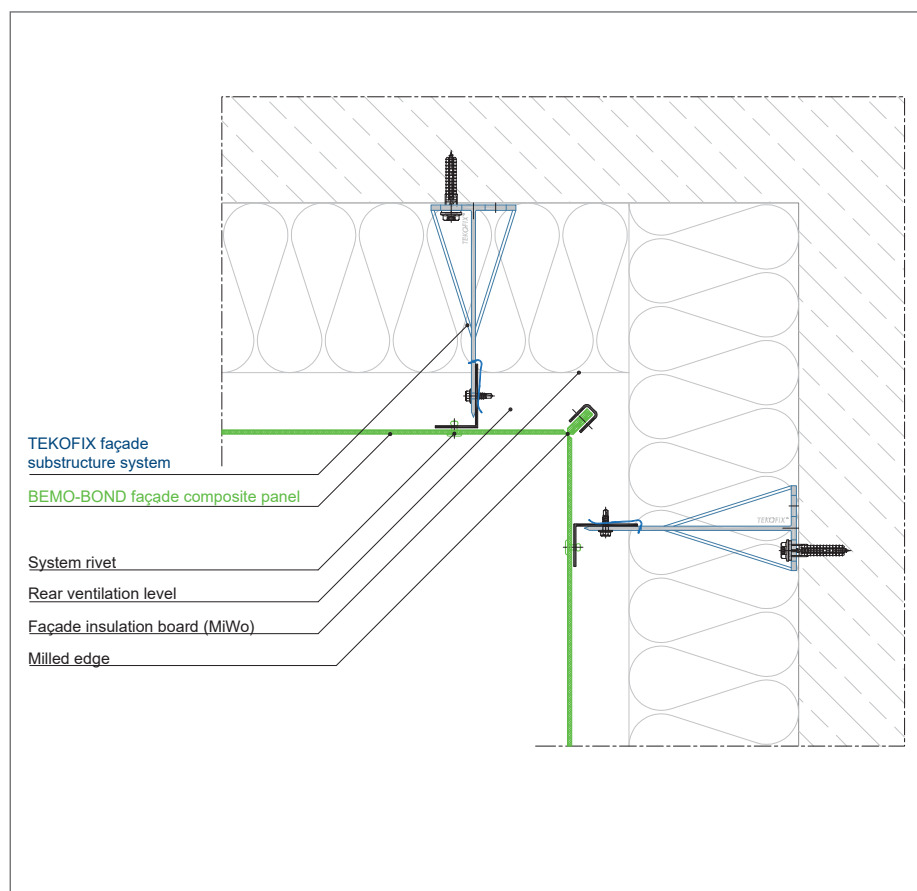
**15. INSPECTION AND MAINTENANCE**

The inspection for stability, damage and proper condition of the material and its execution must be carried out at least once a year. This period may be shorter due to aggressive environments in which the material is constructed.

Whether lack of maintenance or inappropriate cleaning or repair shall release us from our warranty.



**WWW.BEMO.COM**

**BEMO SYSTEMS GmbH**

Max-Eyth-Straße 2

74532 Ilshofen-Eckartshausen

Germany

T: +49 (0) 7904 29899-60

F: +49 (0) 7904 29899-61

E: [sales@bemo.com](mailto:sales@bemo.com)

W: [www.bemo.com](http://www.bemo.com)